

Modero® Touch Panels

5.2" Modero ViewPoint® Wi-Fi Widescreen Touch Panel



The MVP-5150 delivers high-end style and just the right features in a sleek sexy ultra-compact design at a price perfect for any budget. Designed as a low cost alternative to the MVP-5200i, the MVP-5150 is perfect for installations desiring the sleek, sexy design of the MVP-5200i, but do not need all of its features. The MVP-5150 offers both Wi-Fi and one-way IR communication giving the user instant control of virtually any device in the home or office.

ULTRA BRIGHT WIDESCREEN DISPLAY

With 800x480 pixel resolution, the MVP-5150 is our brightest touch panel display. Colors are displayed crisply, clearly and accurately. Its 16x9 screen size provides plenty of widescreen multimedia display options.

WIRELESS CONVENIENCE AND SECURITY

Fully integrated 802.11b/g wireless communications give users outstanding wireless mobility and total system control. And communications remain secure utilizing network security standards including: WEP, WPA, WPA2, EAP-TLS, EAP-TTLS and PEAP.

INCREASED INFRARED CAPABILITY

The MVP-5150 offers a total of ten IR ports: (1) 38kHz AMX port, (1) 455kHz AMX port, and (8) user-defined IR ports for direct communication with 3rd party IR-enabled equipment.

- Ultra-light, compact and thin form factor
- Faster processing and energy efficient
- High-gloss black styling
- Charging options include table charging station (MVP-TCS52) and wall charging station (MVP-WCS52) (kickstand not available)
- Just the right features and just the right price
- (10) IR ports: (1) 38kHz AMX, (1) 455kHz AMX, (8) user IR



MVP-5150 (FG5966-07)

DIMENSIONS (HWD)

4 5/8" x 7 1/2" x 3/4" (11.7 cm x 19.1 cm x 2.0 cm)

POWER

110-240VAC +/- 10%, 50/60Hz

MINIMUM POWER SUPPLY REQUIRED

PS3.0 Power Supply (FG423-30):

All MVP-5150 models are shipped with this power supply

POWER MODES

- ON: All necessary modules are powered up and device remains online with the Netlinx Master.
- STANDBY: LCD/backlight shutdown. Panel resumes the ON mode instantly upon screen touch.
- FULL-OFF: Power to all peripherals and components is turned off. Reboot required to wake.

CERTIFICATIONS

- FCC Part 15 Class B and CE
- IEC60950

BATTERY DURATION

- Three hours of continuous use
- 2.5 days of normal use (25% On, 25% Standby, 50% Off)

MEMORY

- 128 MB NAND FLASH
- 256 MB Mobile DDRAM

WEIGHT

1.2 lbs (0.6 kg)

SCREEN PROPERTIES

- Contrast Ratio: 400:1
- Screen Resolution: 800 x 480 pixels WVGA
- Aspect Ratio: 16 x 9
- Brightness (Luminance): 300 cd/m²
- Display Colors: 262,144 colors (18-bit color depth)
- Dot/Pixel Pitch: 180 dpi
- Panel Type: TFT Color Active-Matrix

VIEWING ANGLE

+/- 60° (horizontal) and + 80°/- 40° (vertical)

OPERATING/STORAGE ENVIRONMENTS

- Operating Temperature: 0° C (32° F) to 40° C (104° F)
- Operating Humidity: 20% - 85% RH
- Storage Temperature: -20° C (-4° F) to 60° C (140° F)
- Storage Humidity: 5% - 85% RH

INCLUDED ACCESSORIES

- PS3.0 Power Supply (FG423-30)
- Stylus (pre-installed onto the left side of the unit)
- Integrated battery

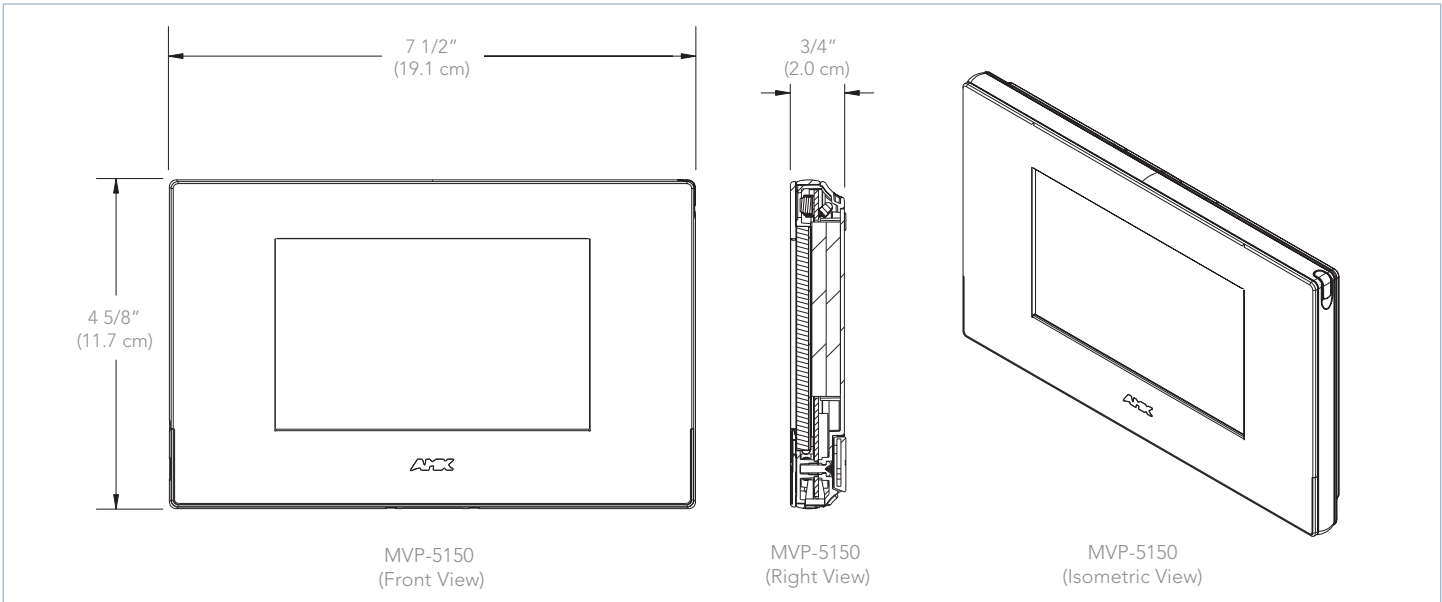

IT'S YOUR WORLD. TAKE CONTROL.